

EXPERIMENTAL INVESTIGATION OF THE DOMESTIC CHP ORC SYSTEM IN TRANSIENT OPERATING CONDITIONS

Grzegorz Żywica, [Tomasz Z. Kaczmarczyk](#), Eugeniusz Ihnatowicz,
Tomasz Turzyński

e-mail: tkaczmarczyk@imp.gda.pl

Milano, 14th September 2017

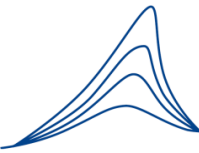

Outline of presentation

1. Introduction
2. Domestic CHP ORC system
3. Experimental results
4. Conclusions

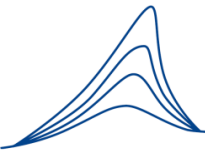

Zakład Dynamiki
i Diagnostyki Turbin

Institute of Fluid-Flow Machinery, Polish Academy of Sciences
Centre of Mechanics of Machines
Department of Turbine Dynamics and Diagnostics



1. Introduction

The main purpose of the research was to analyse operating parameters of a domestic CHP ORC system with a constantly changing demand for heat and electric power (in this way, at the Micro CHP Power Plant Laboratory in Gdańsk, we simulated the conditions that may occur in reality).

It should be noted that, in this case, the power and efficiency levels were not investigated.

2. Characteristics of the domestic CHP ORC system

Basic technical parameters of the tested micro ORC power plant.

Parameter	Value
Fuel type	Biomass (pellets)
Thermal/electric power output	25 kW _t /2.5 kW _e
Expander type	Oil-free vapour microturbine
Working medium (name and type)	HFE-7100, dry fluid
Dimensions, without a boiler (L × W × H))	740 × 740 × 1600 mm

2. Characteristics of the domestic CHP ORC system

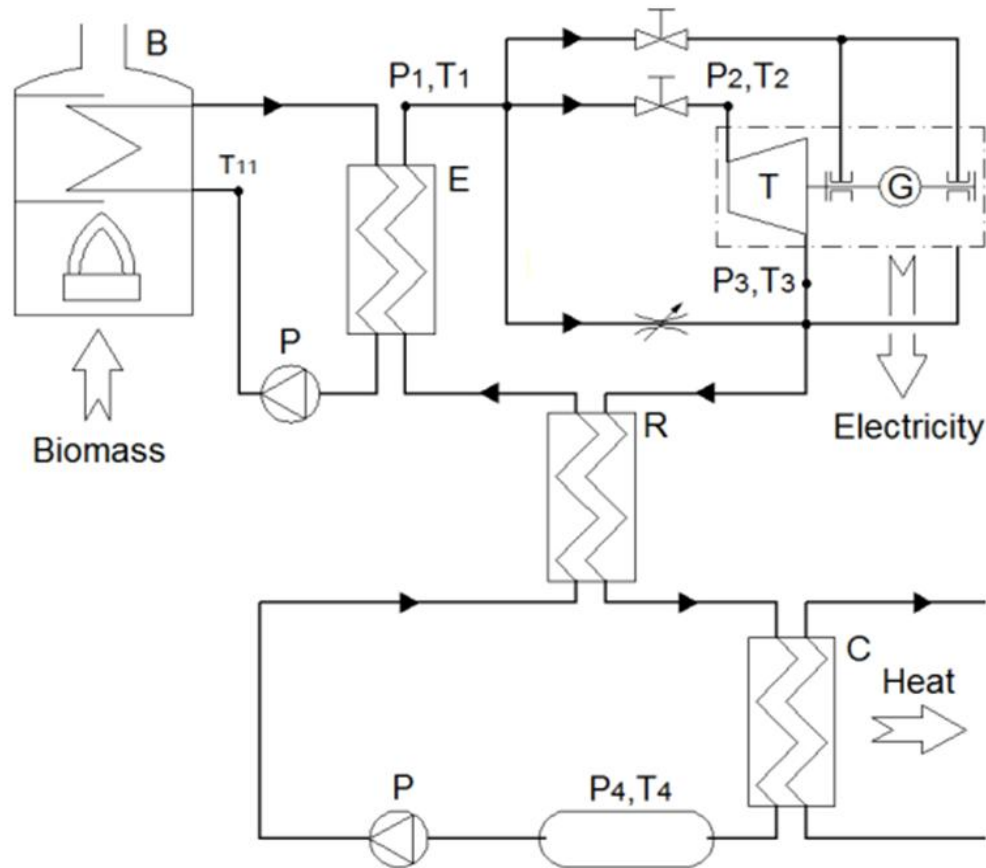
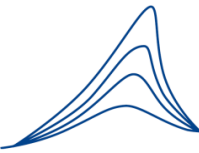

Fig. 1. Scheme of the cycle of the micro ORC power plant: B – boiler, P – pump, E – evaporator, R – regenerator, C – condenser, T – turbine, G – generator.



2. Characteristics of the domestic CHP ORC system



Fig. 2. Photo of the micro ORC power plant.

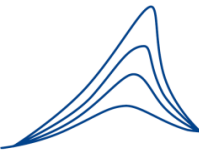

3. Experimental results

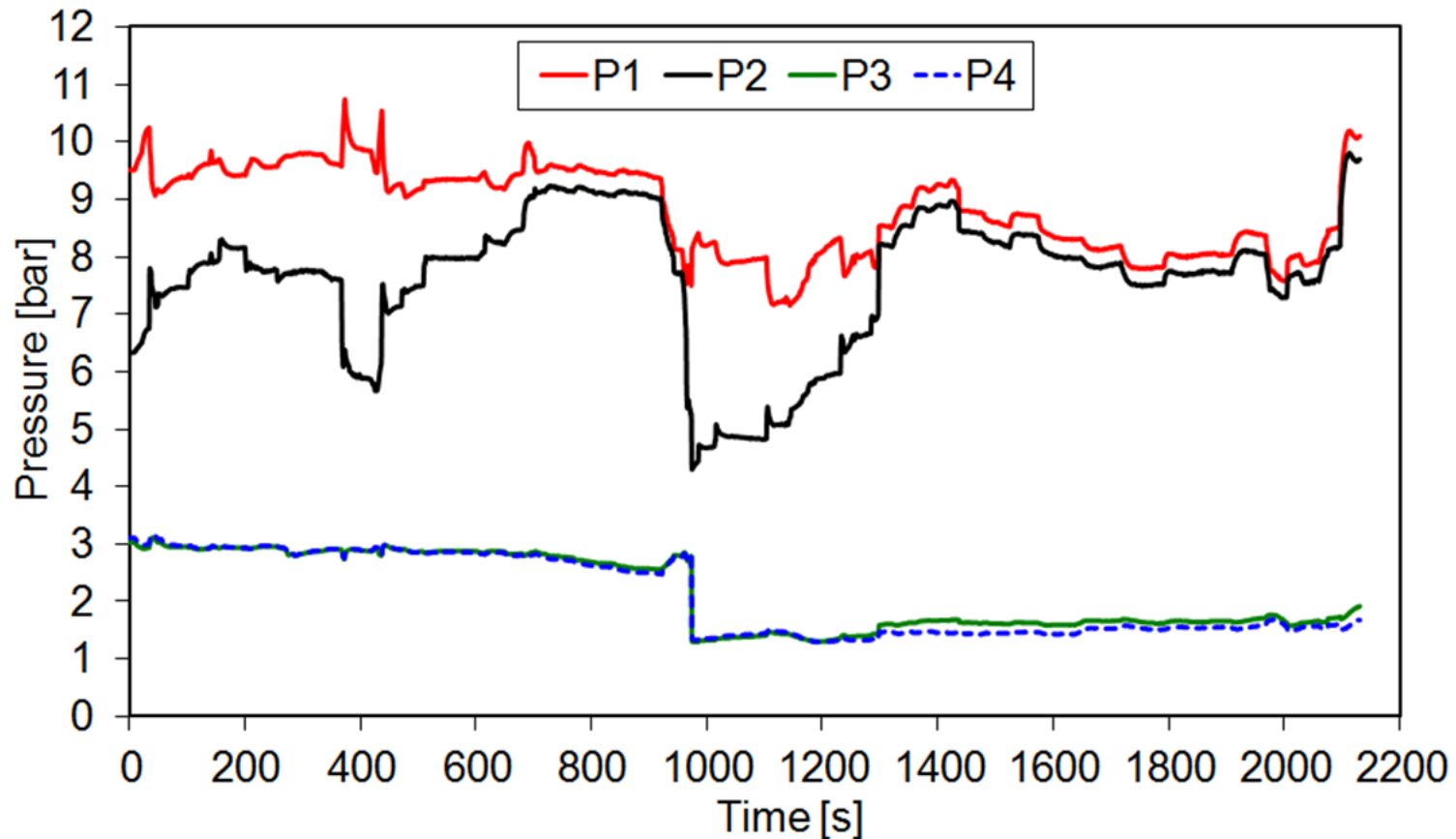
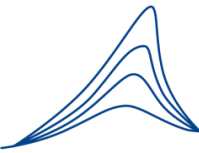

Fig. 3. Pressure of the working medium vs. time: at the evaporator outlet (P1), at the microturbine's inlet (P2) and outlet (P3) and at the condenser outlet (P4).



3. Experimental results

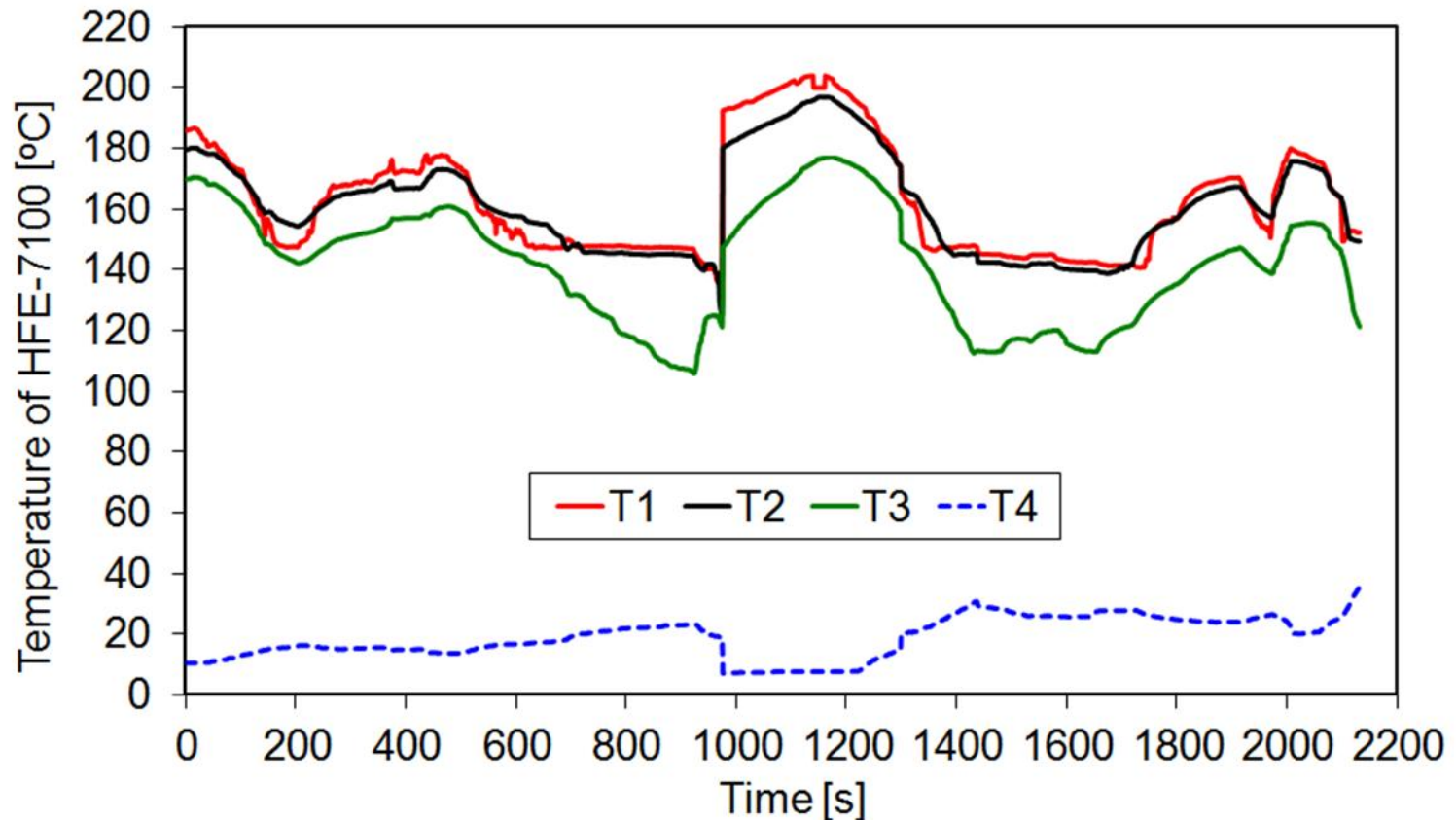

Fig. 4. Temperature of the working medium vs. time: at the evaporator outlet (T1), at the microturbine's inlet (T2) and outlet (T3) and at the condenser outlet (T4).

3. Experimental results

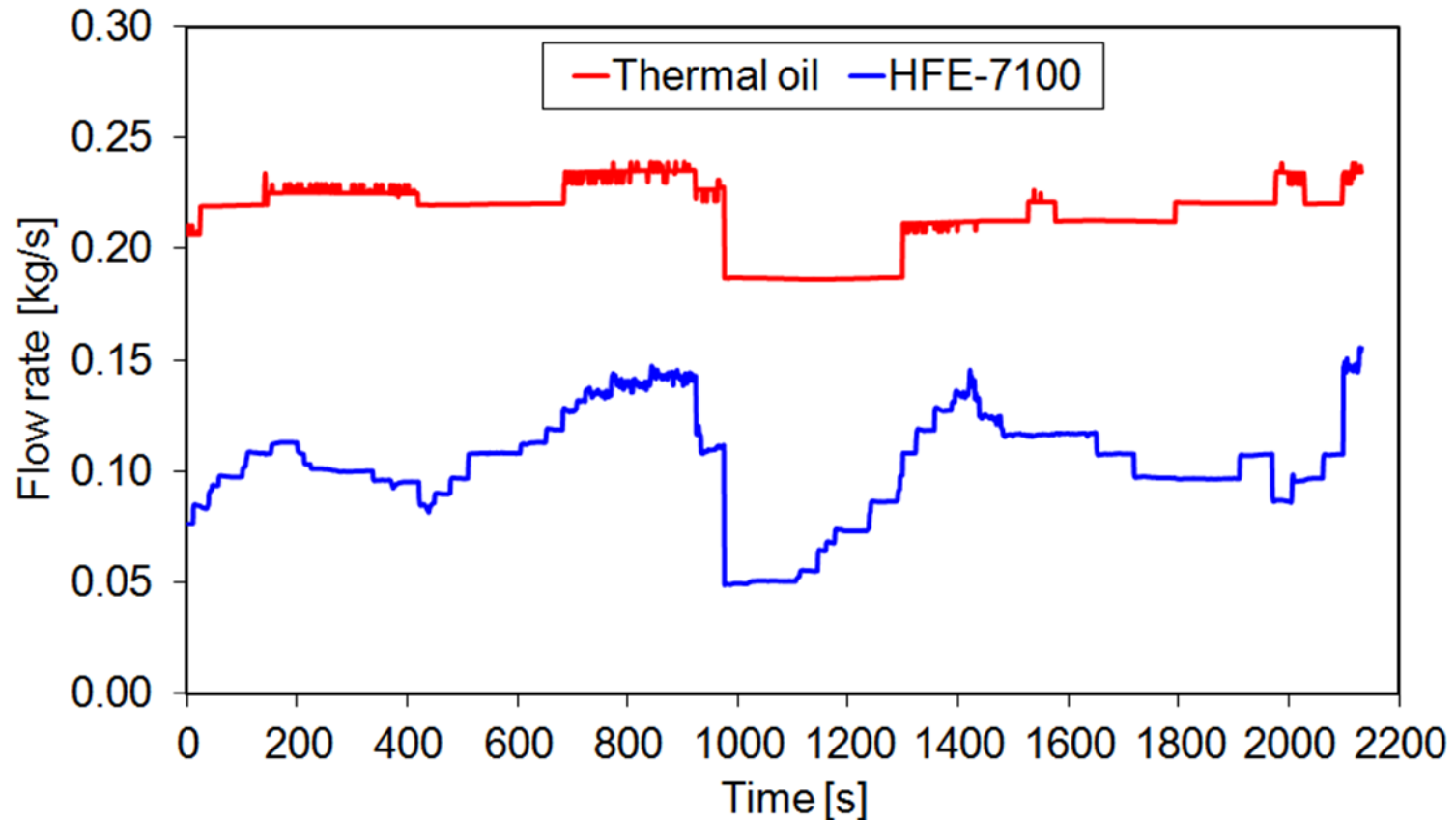
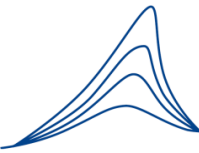

Fig. 5. Flow rates of the working mediums vs. time.



3. Experimental results

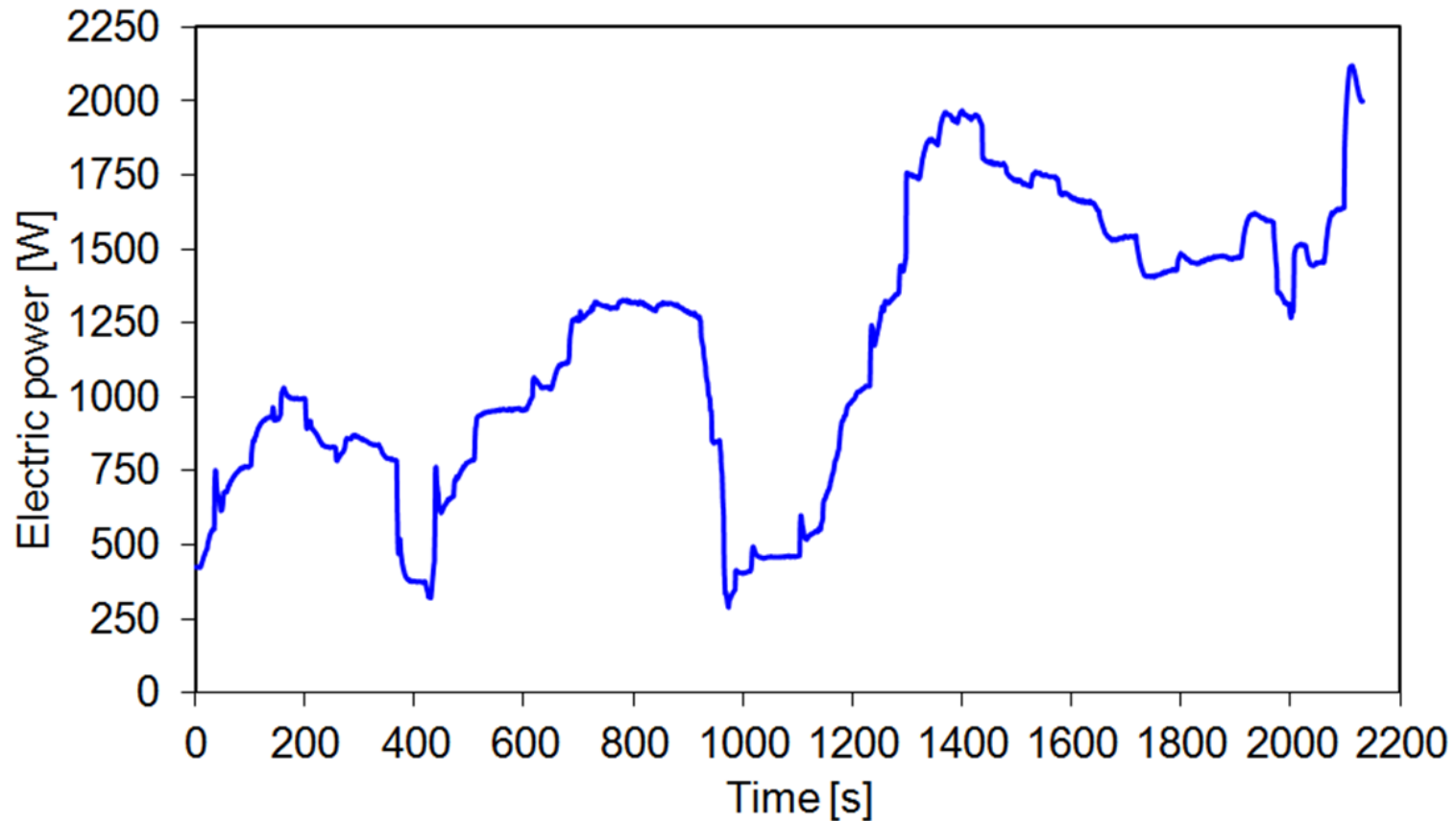

Fig. 6. Electric power produced by the turbogenerator vs. time.

3. Experimental results

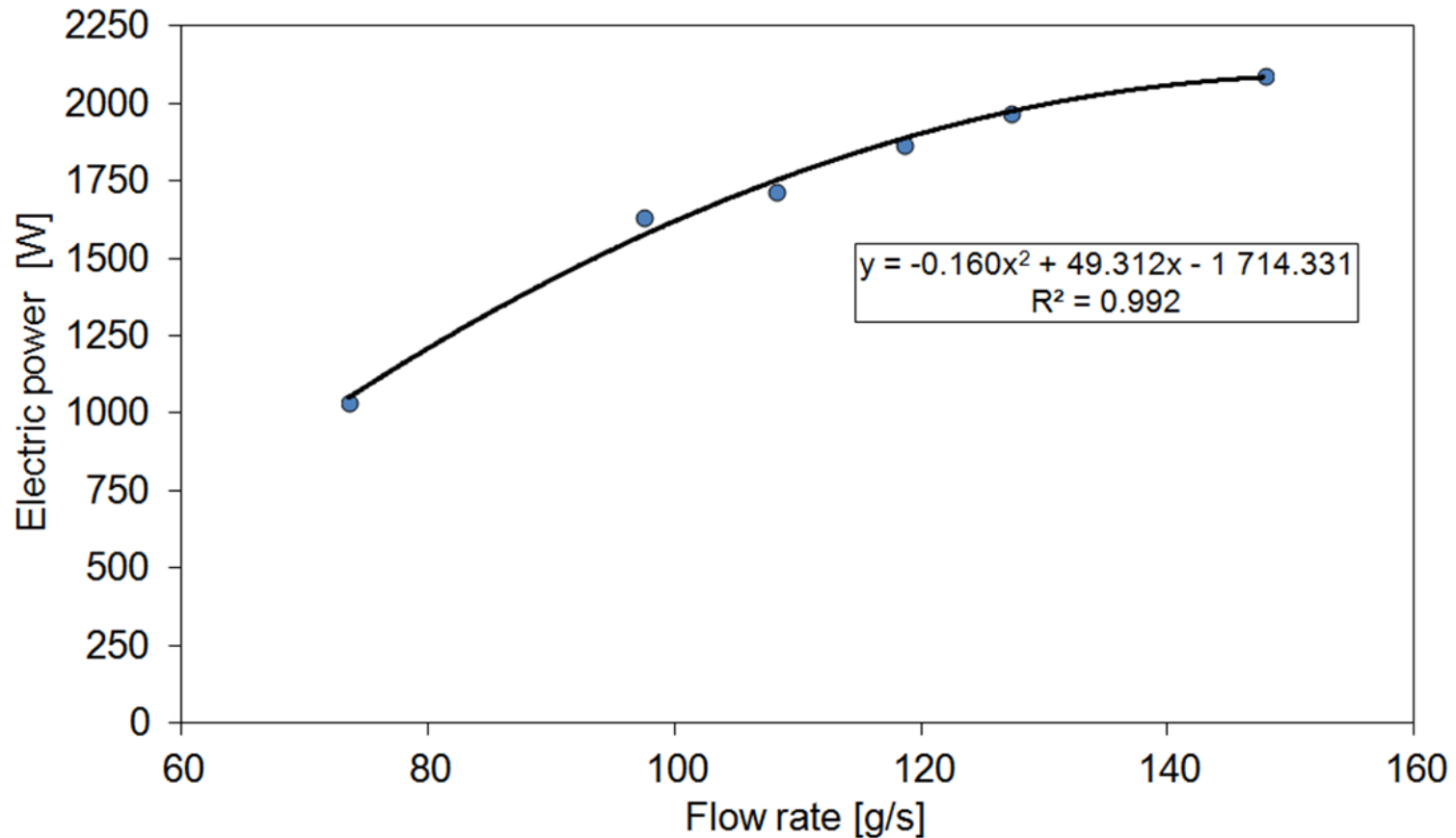

Fig. 7. Electric power generated by the turbogenerator vs. flow rate of the working medium.

3. Experimental results

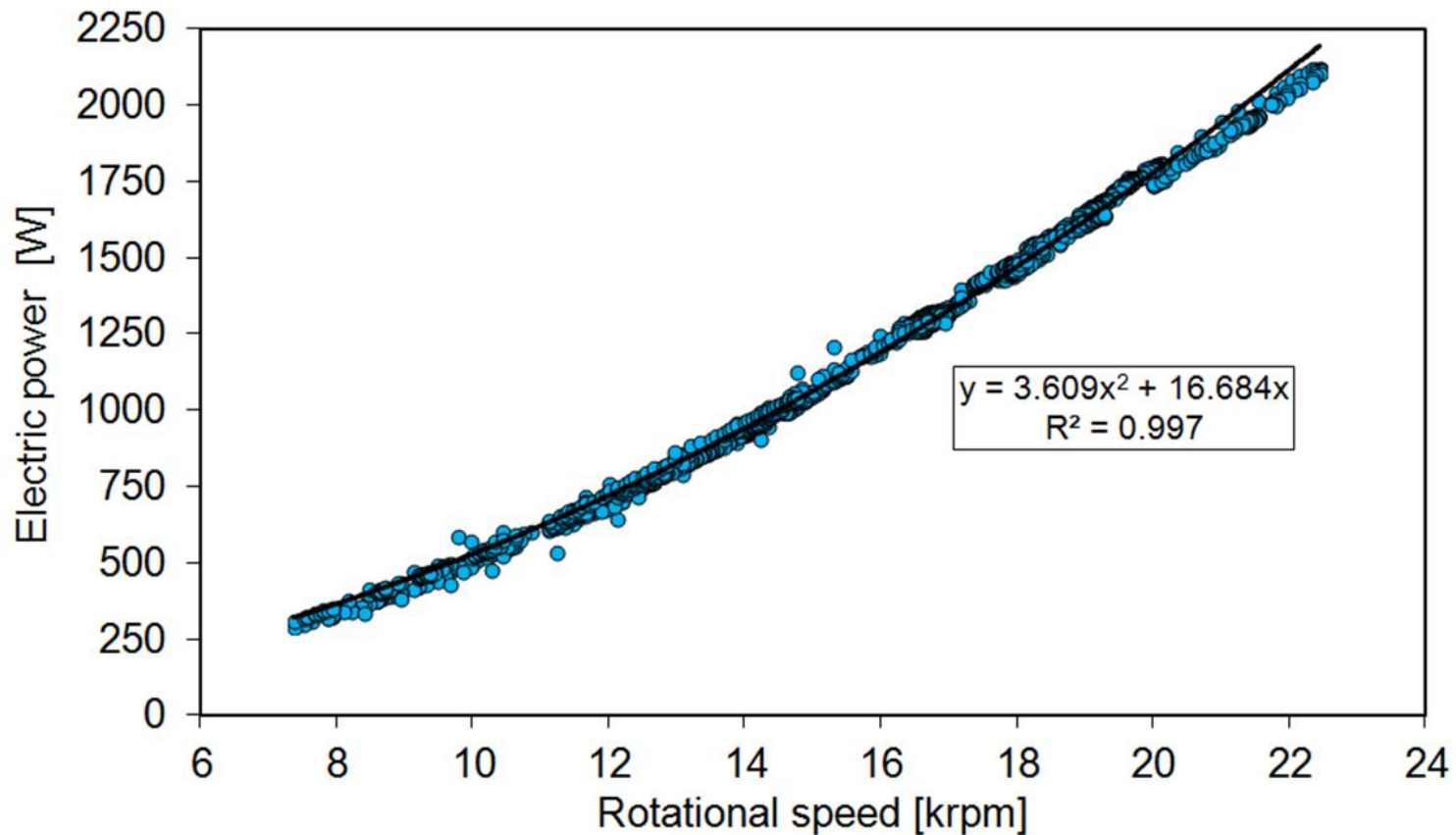
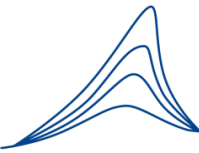

Fig. 8. Electric power generated by the turbogenerator vs. rotational speed.



Zakład Dynamiki
i Diagnostyki Turbin

Institute of Fluid-Flow Machinery, Polish Academy of Sciences
Centre of Mechanics of Machines
Department of Turbine Dynamics and Diagnostics



Short movie

The radial microturbine operating in the ORC system installed on the test bench located at the Institute of Fluid-Flow Machinery of the Polish Academy of Sciences in Gdańsk.

4. CONCLUSIONS

- The maximum gross efficiency of the ORC system was 6.5%,
- The maximum net electric efficiency of the ORC system was 4.5%,
- The internal efficiency of the turbogenerator reached 73%,
- The turbogenerator is capable of operating over a broad speed range (its instantaneous output power can be easily adjusted to the actual electricity demand),
- The developed ORC power system could serve as a basis for the development of a commercial domestic micro-CHP ORC power plant.
- The ORC system has successfully passed tests in simulated real-world conditions (step changes in demand for heat and electricity).

Thank you for your attention

Acknowledgments:

" National Project POIG.01.01.02-00-016/08 *Model agroenergy complexes as an example of distributed cogeneration based on local and renewable sources of energy* " .

"The research work was supported by the strategic program of the National Centre for Research and Development in Poland "Advanced Technologies for Energy Generation" within the Research Task No. 4 – "Developing Integrated Technologies-of Fuel and Energy Production from Biomass, Agricultural Wastes and Other Resources".